

3. Remove the radiator grille and remove the deflector plate as shown at C. Cut away the portions of the grille louvres as shown, so that there is clearance between the Oil Cooler and the grille. If the grille is of the early type with the chromium-plated louvres, no modification to the louvres is required, but it will be necessary to remove the brace frame, and to fabricate and fit a modified brace frame, as shown in Fig.2.

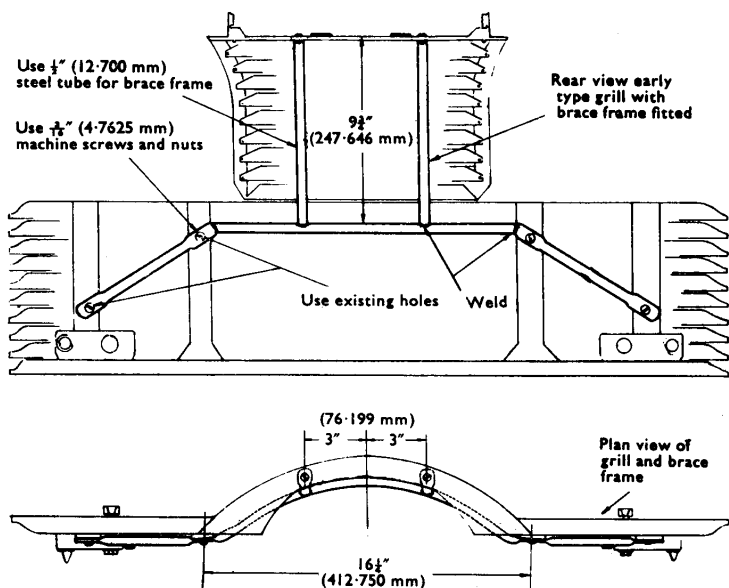

Fig. 2 Fitting of brace frame to early type grill

4. To fit the Cooler, remove the captive nuts at the rear of the mudwing and drill the lower cooler brackets to coincide with the existing holes in the mudwing and secure with two $\frac{1}{4}$ " x 1" BSF bolts and nuts with the distance pieces positioned between the lower Cooler brackets and the mudwing as